

横断用側溝 GLU 基礎寸法及び材料表

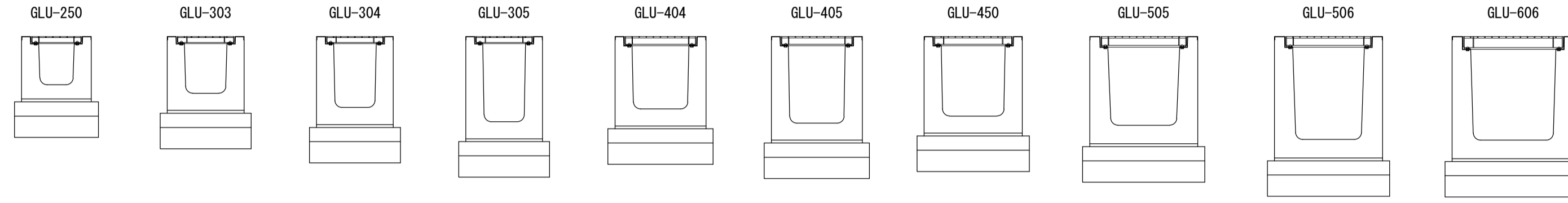

寸法及び単位当り材料表

呼び名	参考重量 (kg)	寸法表 (単位: mm)										製品本数 (本)	材料表 (10m当り)			
		B	b1	b2	b3	b4	b5	b6	H	h1	h2		h3	敷きモルタル (m <sup>2</sup> )	基礎コンクリート (m <sup>3</sup> )	基礎砕石 (m <sup>3</sup> )
GLU-250	666	250	490	120	65	55	230	130	290	100	50	440	5.0	0.098	0.590	5.90
GLU-303	767	300	540	120	65	55	280	130	350	120	50	520	5.0	0.108	0.640	6.40
GLU-304	897	300	540	120	65	55	290	130	450	120	50	620	5.0	0.108	0.640	6.40
GLU-305	1007	300	540	120	65	55	290	130	550	120	50	720	5.0	0.108	0.640	6.40
GLU-404	948	400	640	120	65	55	380	130	445	120	65	630	5.0	0.128	0.740	7.40
GLU-405	1068	400	640	120	65	55	380	130	545	120	65	730	5.0	0.128	0.740	7.40
GLU-450	1031	450	690	120	65	55	430	130	495	120	65	680	5.0	0.138	0.790	7.90
GLU-505	1289	505	760	127.5	75	52.5	460	150	550	130	75	755	5.0	0.152	0.860	8.60
GLU-506	1432	505	760	127.5	75	52.5	460	150	650	130	75	855	5.0	0.152	0.860	8.60
GLU-606	1467	600	860	130	75	55	560	150	640	130	90	860	5.0	0.172	0.960	9.60

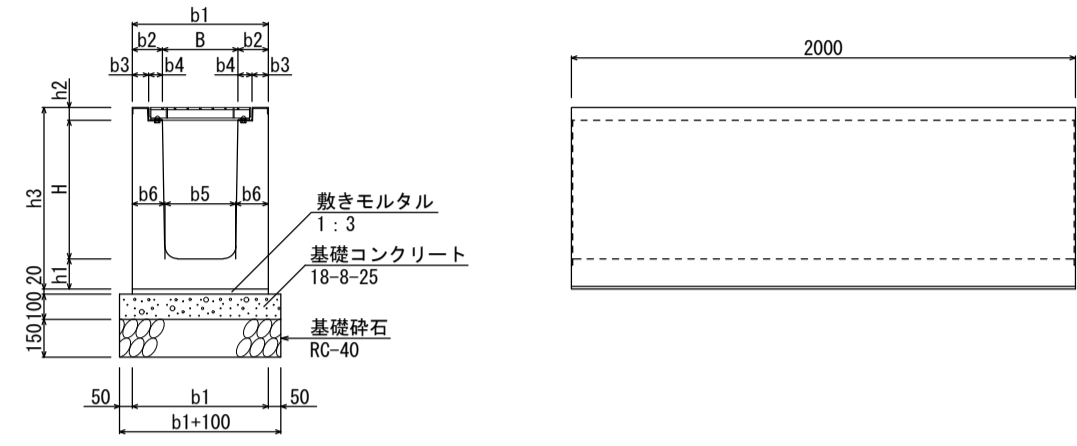
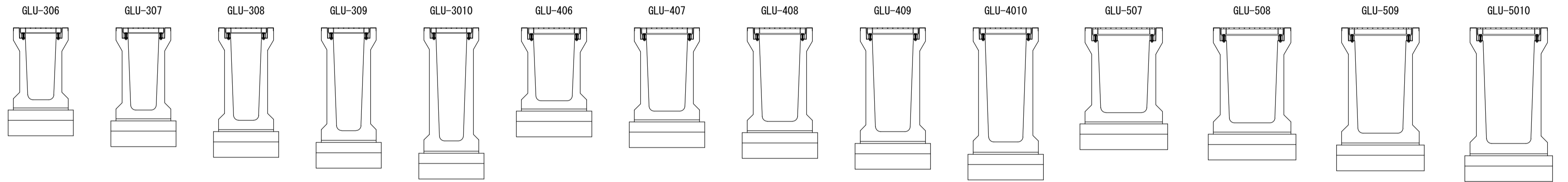
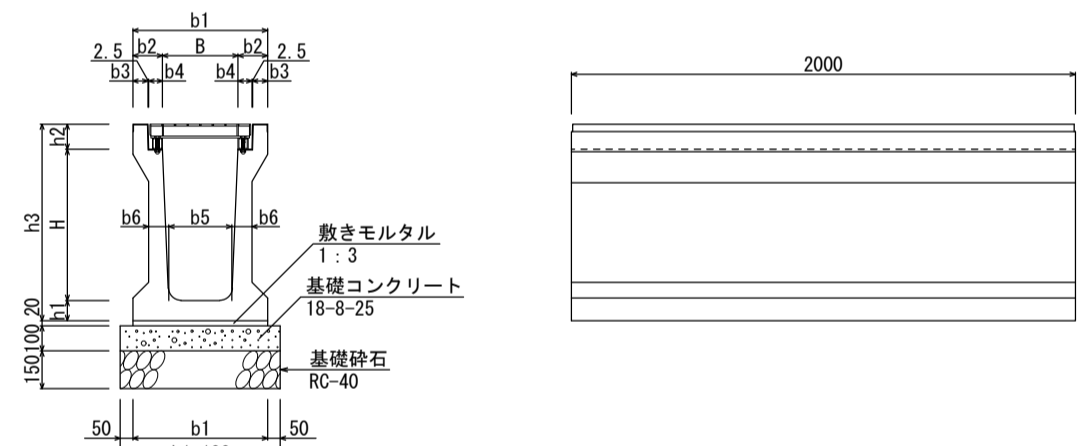
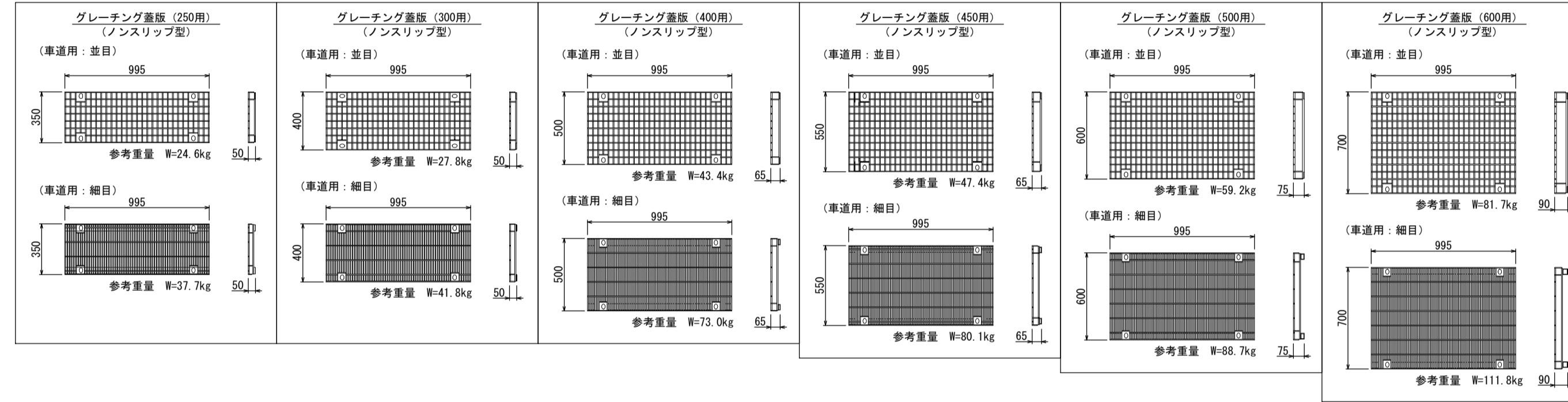

寸法及び単位当り材料表

呼び名	参考重量 (kg)	寸法表 (単位: mm)										製品本数 (本)	材料表 (10m当り)			
		B	b1	b2	b3	b4	b5	b6	H	h1	h2		h3	敷きモルタル (m <sup>2</sup> )	基礎コンクリート (m <sup>3</sup> )	基礎砕石 (m <sup>3</sup> )
GLU-306	727	300	535	117.5	60	55	250	80	800	80	100	780	5.0	0.107	0.635	6.35
GLU-307	825	300	535	117.5	60	55	245	85	700	85	100	685	5.0	0.107	0.635	6.35
GLU-308	930	300	535	117.5	60	55	240	90	800	90	100	990	5.0	0.107	0.635	6.35
GLU-309	1043	300	535	117.5	60	55	235	95	900	95	100	1095	5.0	0.107	0.635	6.35
GLU-3010	1163	300	535	117.5	60	55	230	100	1000	100	100	1200	5.0	0.107	0.635	6.35
GLU-406	770	400	635	117.5	60	55	350	80	600	80	110	790	5.0	0.127	0.735	7.35
GLU-407	872	400	635	117.5	60	55	345	85	700	85	110	895	5.0	0.127	0.735	7.35
GLU-408	979	400	635	117.5	60	55	340	90	800	90	110	1000	5.0	0.127	0.735	7.35
GLU-409	1095	400	635	117.5	60	55	335	95	900	95	110	1105	5.0	0.127	0.735	7.35
GLU-4010	1217	400	635	117.5	60	55	330	100	1000	100	110	1210	5.0	0.127	0.735	7.35
GLU-507	997	500	755	127.5	65	60	445	90	700	90	125	915	5.0	0.151	0.855	8.55
GLU-508	1065	500	755	127.5	65	60	440	90	800	90	125	1015	5.0	0.151	0.855	8.55
GLU-509	1183	500	755	127.5	65	60	435	95	900	95	125	1120	5.0	0.151	0.855	8.55
GLU-5010	1307	500	755	127.5	65	60	430	100	1000	100	125	1225	5.0	0.151	0.855	8.55

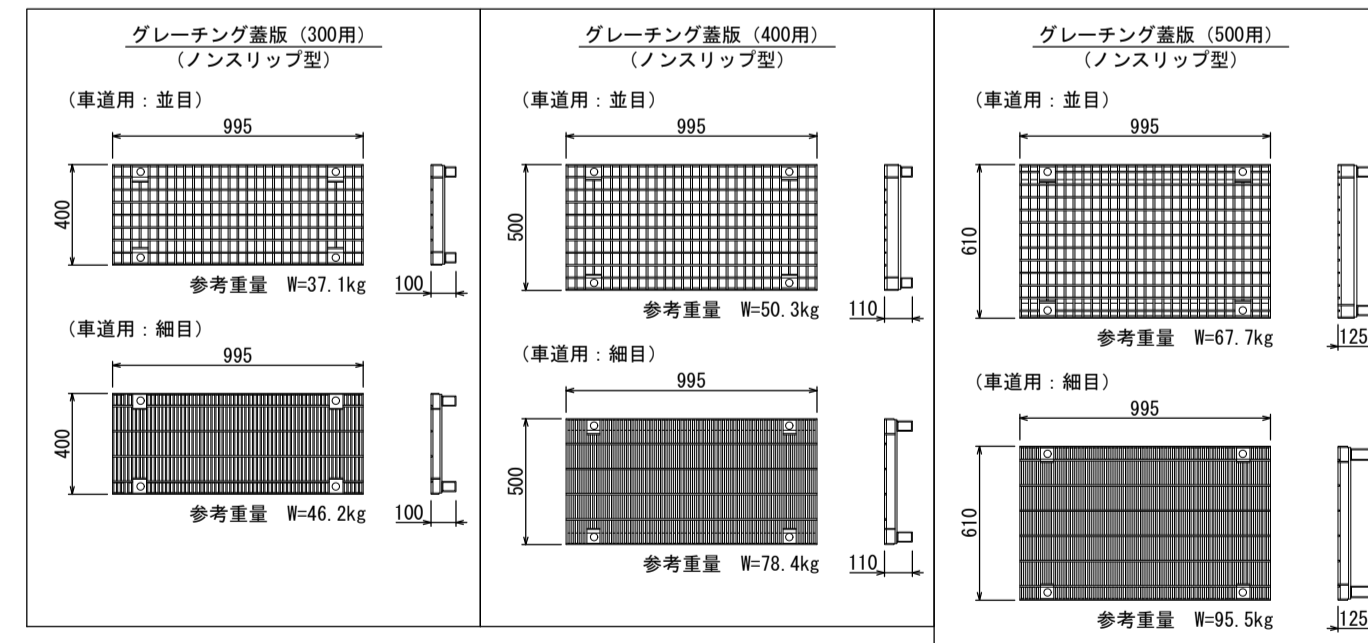

名称	横断用側溝 GLU		
縮尺	1:30	日付	2022.9.1
会社名	藤岡コンクリート工業株式会社		

